



Yiwu Xinyuan Technology Co.,Ltd.

Tel:+86 188 6816 8090 (Kris)

Email:kris@xypedestal.com

Web:www.xypedestal.com

Add:Intelligence Pioneer Park,Fotang Town,Yiwu,China

Adjustable Pedestal XY-M0-TA Data Sheet

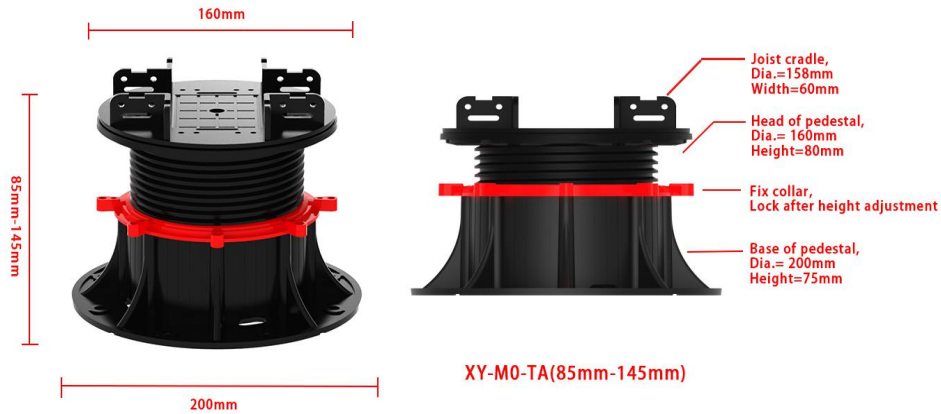

XY-M0-TA(85mm-145mm)

Composition

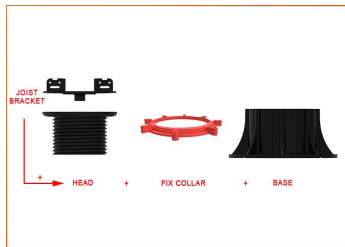

1 head(80mm)+ 1 joist cradle +1 fix collar +1 base(75mm)

Details

Joist cradle  
diameter=158mm  
width=60mm

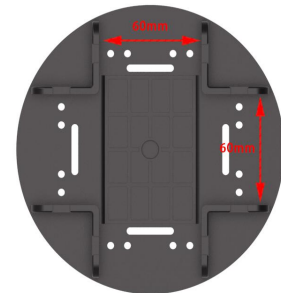

Height Range

85mm-145mm

Slope corrector:  
compensate  
slope 0%-5%

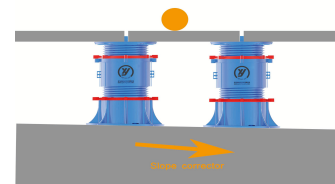

Material

Composition:90%PP,10% talc,UV adn black masterbatch;  
100% recyclable

Performances

Resisting UV rays,weather, sea salt and almost all chemicals  
Temperature range :-40°C to 120°C

Fix collar:  
fix and lock  
height after  
adjustment,  
increase stability  
of pedestal



Red collar,  
customized collar  
accept.  
Made of PP

Application area

Support for outdoor terraces with any kind of material:timber decking,  
stone,ceramic,composite materials,metal, fiberglass grid.  
Can be placed on any stable substrate,aslo over insulation panels.

Compression test

Performed on the full(1/1),half(1/2)and quarter(1/4) surface of the head

Position	Height(mm)	Breaking Load(kgs)
1/1	85	4500
1/2	85	4000
1/4	85	2000

Slope corrector

Slope corectors could compensate ground fall 0%-5%  
making ideal levelling surface.  
choose to use it or not with different installing conditions.

Weight(g/set)

joist cradle	120	head	230
fix collar	29	base	295
Total		674	

Safety value for maximum allowable load by compression for XY-M0-TA:  
★Safety for pedestrian terraces:divide the load indicated in the table by 2  
with a safety factor of -15%  
★Safety for technical floor:divide the load indicated in the table by 4  
with a safety factor of -15%